

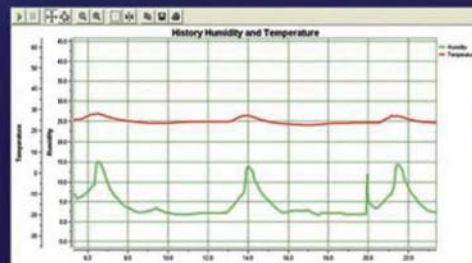

CHANGSHU CATEC ELECTRONIC EQUIPMENT INC

CATEC Top Dry Cabinets & Equipment For Moisture Sensitive Device (MSD) Storage.

- ◆ **Auto Dry Cabinets**
- ◆ **N₂ Gas Cabinets**
- ◆ **Humidity & Temperature Monitors**
- ◆ **Drying Ovens**
- ◆ **Safety Cabinets for Flammables**
- ◆ **Customized high quality and professional dehumidifying solutions**



ISO9001

2013 Version



We are manufacturer for various types of dry cabinets, nitrogen cabinets, drying ovens, safety cabinets, and other electronic equipment. We have powerful professional team with long years of experience in the field of humidity control industry.

We enriched our experience and knowledge in over 10yrs of sustainable working. We understand our clients' need, requirement and international standards quite well. With modern equipments, advanced technology, strict quality control in production and constant technical innovating, CATEC products are welcoming in worldwide markets and become popular in many fields, such as micro-electronics, electronics, war industry, chemical industry, research institute etc. We've been the best supplier for world brands like BenQ, ASUS, BYD, HITACHI, SHARP, OMRON, LOGITECH, Saint-Gobain, MOTOROLA, P2i, EUROINTECH, TCL, NOKIA, HUAWEI. etc. We are having strong confidence to supply our clients worldwide with best quality-price ratio and excellent over-all service.

CATEC ELECTRONIC, TECHNOLOGY KEEPING AHEAD, QUALITY SERVING CUSTOMERS !



● Are your MSD safely stored?

As humidity is found to be one of the key reasons for rejected products, many manufacturers are taking measures to control the humidity to increase their production efficiency and save the cost. In the industries of semi-conductor and electronics, the key section in which the rejected products are most probably to be made is that during the heating process of SMT, the IC(e.g., PBGA, BGA, or TQFD) is likely to crack and thus cause non-effective welding because of the humidity. CATEC auto dry cabinet is the best solution to avoid the cracking and non-effective welding by dehumidifying the surface of your components.

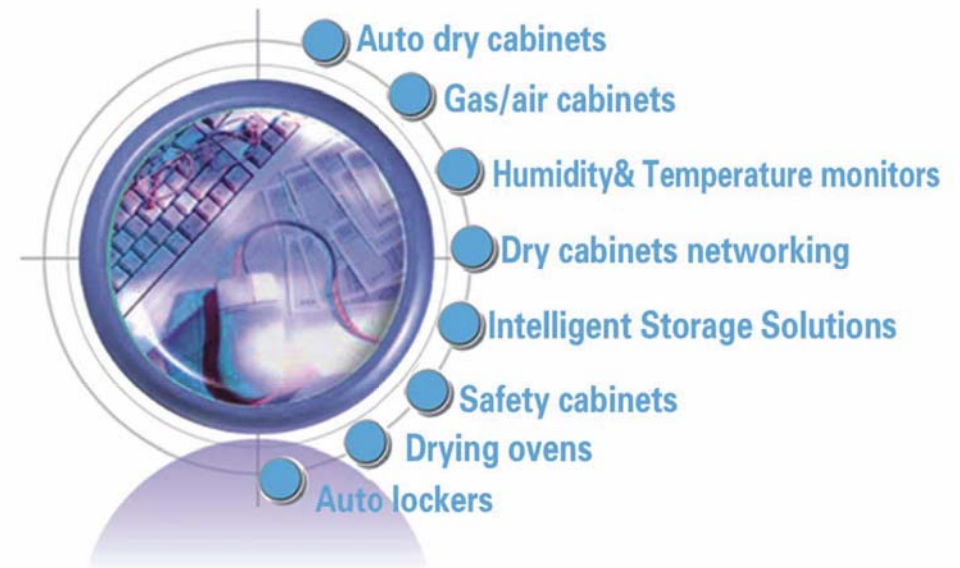
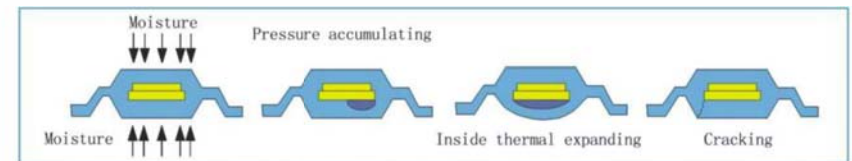

- LED display, Honeywell humidity sensor with error as $\pm 3\%$ RH.
- Quality 1mm and 1.2mm cold rolled steel, reinforced structure, high intensity bearing, every shelf can bear over 40kg load.
- 3.2mm tempered glass.
- Zinc alloy lock with air press.
- ROHS certified powder coating technology with Dupont powder, high anti-erosion performance to avoid your stored goods from pollution and static shock.
- AC power 85V~265V 50/60Hz, compatible for worldwide application.
- Smart Control System and resettable target humidity.
- Compliant with IPC/JEDEC J-STD-033B, and CE certified.
- Options for customer's special demands:
 - 1) data logging system by USB connection with computer for data reading and printing;
 - 2) security code lock;
 - 3) alarm system with light tower;
 - 4) heating system up to 40°C, for low temperature baking;
 - 5) high flow air injection system for up to 300LPM;
 - 6) independent segregated compartments.
 - 7) stainless steel cabinet.

U type: ultra low humidity control, less than 5%RH

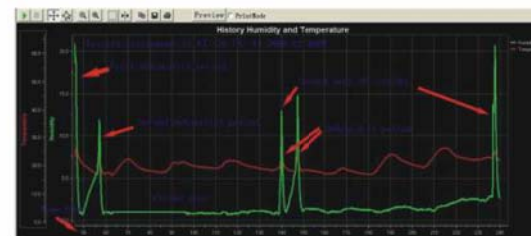

Dry98 Series



Outer dimension:W448*D400*H688mm

Inner dimension:W446*D372*H598mm

Display Panel

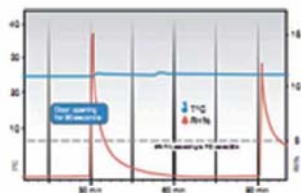

Product Name	Type	Controlled Scope	Control Mode
Medium humidity dry cabinet	A	20~60%RH	Adjustable pointing control
Low humidity dry cabinet	B	10~20%RH	Adjustable pointing control
Ultra-low humidity dry cabinet	C	1~10%RH	Automatic
	U	1~5%RH	
Automatic nitrogen cabinet	D	1~60%RH	Precise pointing control

D type is to be seen on P10-11

SPEC	Controlled Humidity (RH)	Average Power (W)	Maximum Power (W)	Anti-ESD Function (Y/N)
DRY98A	20%~60%	13	91	N
DRY98B	10%~20%	18	126	N
DRY98C	1%~10%	18	126	N
DRY98U	1%~5%	18	126	N
DRY98EA	20%~60%	13	91	Y
DRY98EB	10%~20%	18	126	Y
DRY98EC	1%~10%	18	126	Y
DRY98EU	1%~5%	18	126	Y

Dry160 Series



Outer dimension:W448*D450*H1010mm
 Inner dimension:W446*D422*H848mm

Dry240 Series



Outer dimension:W598*D400*H1310 mm
 Inner dimension:W596*D372*H1148 mm

SPEC	Controlled Humidity (RH)	Average Power (W)	Maximum Power (W)	Anti-ESD Function (Y/N)
DRY160A	20%~60%	18	126	N
DRY160B	10%~20%	18	126	N
DRY160C	1%~10%	20	140	N
DRY160U	1%~5%	20	140	N
DRY160EA	20%~60%	18	126	Y
DRY160EB	10%~20%	18	126	Y
DRY160EC	1%~10%	20	140	Y
DRY160EU	1%~5%	20	140	Y

SPEC	Controlled Humidity (RH)	Average Power (W)	Maximum Power (W)	Anti-ESD Function (Y/N)
DRY240A	20%~60%	18	126	N
DRY240B	10%~20%	18	126	N
DRY240C	1%~10%	20	140	N
DRY240U	1%~5%	20	140	N
DRY240EA	20%~60%	18	126	Y
DRY240EB	10%~20%	18	126	Y
DRY240EC	1%~10%	20	140	Y
DRY240EU	1%~5%	20	140	Y

Dry320 Series

Outer dimension:W900*D450*H1010 mm

Inner dimension:W898*D422*H848 mm

SPEC	Controlled Humidity (RH)	Average Power (W)	Maximum Power (W)	Anti-ESD Function (Y/N)
DRY320A	20%~60%	20	140	N
DRY320B	10%~20%	20	140	N
DRY320C	1%~10%	40	280	N
DRY320U	1%~5%	40	280	N
DRY320EA	20%~60%	20	140	Y
DRY320EB	10%~20%	20	140	Y
DRY320EC	1%~10%	40	280	Y
DRY320EU	1%~5%	40	280	Y



Dry435 Series

Outer dimension:W900*D600*H1010 mm

Inner dimension:W898*D572*H848 mm

SPEC	Controlled Humidity (RH)	Average Power (W)	Maximum Power (W)	Anti-ESD Function (Y/N)
DRY435A	20%~60%	20	140	N
DRY435B	10%~20%	20	140	N
DRY435C	1%~10%	40	280	N
DRY435U	1%~5%	40	280	N
DRY435EA	20%~60%	20	140	Y
DRY435EB	10%~20%	20	140	Y
DRY435EC	1%~10%	40	280	Y
DRY435EU	1%~5%	40	280	Y



Dry540 Series



Outer dimension:W598*D710*H1465 mm

Inner dimension:W596*D682*H1298 mm

SPEC	Controlled Humidity (RH)	Average Power (W)	Maximum Power (W)	Anti-ESD Function (Y/N)
DRY540A	20%~60%	20	140	N
DRY540B	10%~20%	40	280	N
DRY540C	1%~10%	60	420	N
DRY540U	1%~5%	60	420	N
DRY540EA	20%~60%	20	140	Y
DRY540EB	10%~20%	40	280	Y
DRY540EC	1%~10%	60	420	Y
DRY540EU	1%~5%	60	420	Y

Dry718 Series



Outer dimension:W598*D710*H1910 mm

Inner dimension:W596*D682*H1723 mm

SPEC	Controlled Humidity (RH)	Average Power (W)	Maximum Power (W)	Anti-ESD Function (Y/N)
DRY718A	20%~60%	20	140	N
DRY718B	10%~20%	40	280	N
DRY718C	1%~10%	60	420	N
DRY718U	1%~5%	60	420	N
DRY718EA	20%~60%	20	140	Y
DRY718EB	10%~20%	40	280	Y
DRY718EC	1%~10%	60	420	Y
DRY718EU	1%~5%	60	420	Y

Dry870 Series

Outer dimension:W900*D600*H1890 mm
 Inner dimension:W898*D572*H1698 mm



SPEC	Controlled Humidity (RH)	Average Power (W)	Maximum Power (W)	Anti-ESD Function (Y/N)
DRY870A	20%~60%	40	280	N
DRY870B	10%~20%	40	280	N
DRY870C	1%~10%	80	560	N
DRY870U	1%~5%	80	560	N
DRY870EA	20%~60%	40	280	Y
DRY870EB	10%~20%	40	280	Y
DRY870EC	1%~10%	80	560	Y
DRY870EU	1%~5%	80	560	Y

Dry1436 Series

Outer dimension:W1200*D710*H1910 mm
 Inner dimension:W1198*D682*H1723 mm



SPEC	Controlled Humidity (RH)	Average Power (W)	Maximum Power (W)	Anti-ESD Function (Y/N)
DRY1436A-4/DRY1436A-6	20%~60%	40	280	N
DRY1436B-4/DRY1436B-6	10%~20%	80	560	N
DRY1436C-4/DRY1436C-6	1%~10%	120	840	N
DRY1436U-4/DRY1436U-6	1%~5%	120	840	N
DRY1436EA-4/DRY1436EA-6	20%~60%	40	280	Y
DRY1436EB-4/DRY1436EB-6	10%~20%	80	560	Y
DRY1436EC-4/DRY1436EC-6	1%~10%	120	840	Y
DRY1436EU-4/DRY1436EU-6	1%~5%	120	840	Y

- Compound Dry Cabinet with timer and buzzer
down counting for up to 9999minutes to ensure the drying efficiency



- Dry Cabinet in Stainless Steel



- Special Door/Display/Drawer



- Dry Cabinets with Independent Spaces

Segregated individual compartments, when you open one door, the others won't be effected.



- Dry cabinet with heating system for up to 40°C



- We are interested in meeting the increasing demands for your individual solution

We would try all the best to serve you with products of low energy consumption and environment-friendly value.



DRY118 Series

Outer dimension:W448*D550*H658mm

SPEC	Controlled Humidity (RH)	Average Power (W)	Maximum Power (W)	Anti-ESD Function (Y/N)
DRY118A	20%~60%	18	126	N
DRY118B	10%~20%	18	126	N
DRY118C	1%~10%	20	140	N
DRY118EA	20%~60%	18	126	Y
DRY118EB	10%~20%	18	126	Y
DRY118EC	1%~10%	20	140	Y



DRY178 Series

Outer dimension:W448*D550*H932mm

SPEC	Controlled Humidity (RH)	Average Power (W)	Maximum Power (W)	Anti-ESD Function (Y/N)
DRY178A	20%~60%	18	126	N
DRY178B	10%~20%	18	126	N
DRY178C	1%~10%	20	140	N
DRY178EA	20%~60%	18	126	Y
DRY178EB	10%~20%	18	126	Y
DRY178EC	1%~10%	20	140	Y



DRY238 Series

Outer dimension:W448*D550*H1206mm

SPEC	Controlled Humidity (RH)	Average Power (W)	Maximum Power (W)	Anti-ESD Function (Y/N)
DRY238A	20%~60%	18	126	N
DRY238B	10%~20%	18	126	N
DRY238C	1%~10%	20	140	N
DRY238EA	20%~60%	18	126	Y
DRY238EB	10%~20%	18	126	Y
DRY238EC	1%~10%	20	140	Y

Display Panel

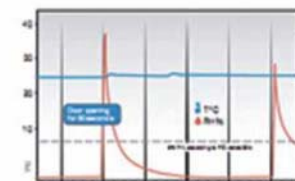

- Suitable for office of information technology, electronics, research and development, ISO documentation centers, etc. for damp-proof storage of office items.
- Used for Network, Imaging disks, CD-ROM, microform, sound recording and other information.
- Specially used for CD, MO, disk, software, slides, video tapes, professional paper, special artwork and photographic equipment.
- Drawers with ball track , each drawer can load over 50kg.
- Standard adjustable support and universal removable casters.

- LED display, Honeywell humidity sensor with error as $\pm 3\%RH$.
- Quality 1mm and 1.2mm cold rolled steel, reinforced structure design, high intensity bearing.
- 3.2mm tempered glass.
- Zinc alloy lock with air press.
- High intensity truckle with brake.
- RoHs certified advanced powder coating technology with Dupont powder, high anti-erosion performance to avoid your stored goods from pollution, static shock, and oxidation.
- AC power 85V~265V 50/60Hz.
- Available for nitrogen gas or compressed air for 1~60%RH.
- Options for air flow ranges: 5~25LPM, 5~60LPM, 5~300LPM.

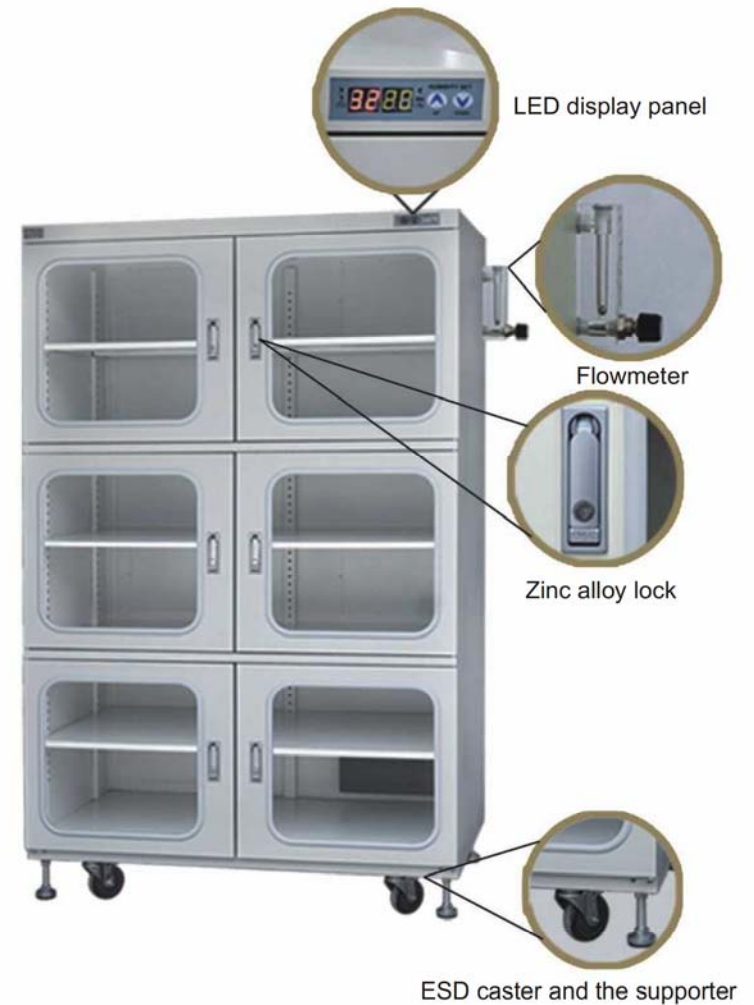

Controlled Humidity(RH):1%~60%
Average Power(W):8



DRY98D
DRY98ED

Outer dimension:
W448*D400*H688
Inner dimension:
W446*D372*H598



DRY160D
DRY160ED

Outer dimension:
W448*D450*H1010
Inner dimension:
W446*D422*H848



DRY240D
DRY240ED

Outer dimension:
W598*D400*H1310
Inner dimension:
W596*D372*H1148



DRY320D
DRY320ED

Outer dimension:
W900*D450*H1010
Inner dimension:
W898*D422*H848



DRY435D
DRY435ED

Outer dimension:
W900*D600*H1010
Inner dimension:
W898*D572*H848



DRY540D
DRY540ED

Outer dimension:
W598*D710*H1465
Inner dimension:
W596*D682*H1298



DRY718D
DRY718ED

Outer dimension:
W598*D710*H1910
Inner dimension:
W596*D682*H1723



DRY870D
DRY870ED

Outer dimension:
W900*D600*H1890
Inner dimension:
W898*D572*H1698



DRY1436D-4
DRY1436ED-4

Outer dimension:
W1200*D710*H1910
Inner dimension:
W1198*D682*H1723



DRY1436D-6
DRY1436ED-6

Outer dimension:
W1200*D710*H1910
Inner dimension:
W1198*D682*H1723

- Specs for your options: CTT-18D, CTT-18DU, CTT-18DUT.
- Temperature range: -9.9°C~+70°C Temperature display deviation: ±1°C
- Humidity range: 0.1%RH~99.9%RH Humidity display deviation: ±3%RH
- Input voltage: AC85V~265V
- High accuracy sensor.
- Ultra low power consume, less than 5W.
- Convenient for wall hanging.
- 4 inches super high luminance digital LED, visible clearly from over 30 meters.
- Resettable limitation for alarming. Your setting will be well kept even after power off. Alarm mode is high decibel buzzer (>70dB) .
- Good memory for data of temperature and humidity up to 250 hours, readable on your PC via USB connection with associated drive software.

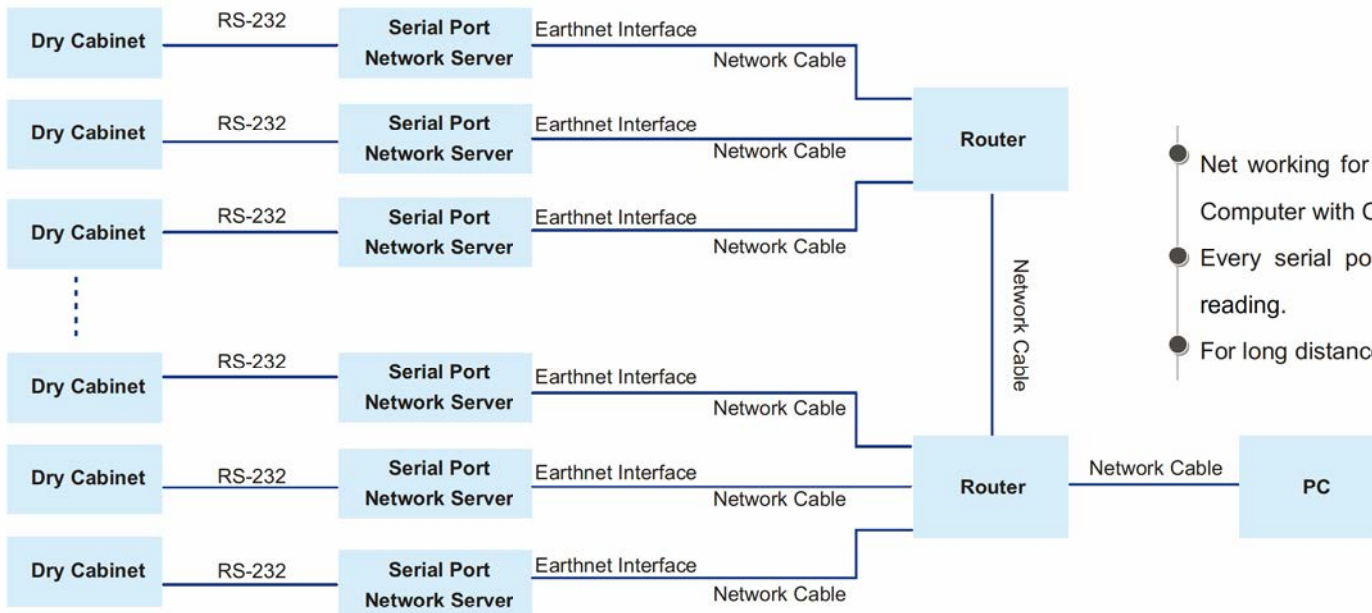
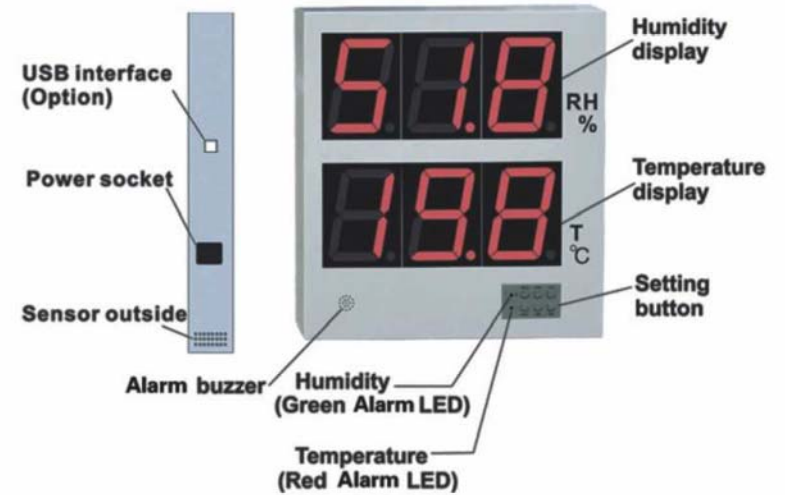

- Net working for up to 253 units of dry cabinets, controlled via ONE Computer with CATEC software, readable for the data up to 800 hrs.
- Every serial port network server has a static IP address for data reading.
- For long distance, you can use a router for signal booster.

CATEC dry box, the expert for storing your camera and other Moisture Sensitive Items

- LED display, Honeywell humidity sensor with relative humidity deviation as $\pm 3\%RH$.
- 1mm and 1.2mm cold rolled Steel, reinforced structure, high intensity bearing, every shelf can bear over 40kg load.
- 3.2mm tempered glass.
- Safe key locking.
- ROHS certified powder coating technology with Dupont powder, high anti-erosion performance to avoid your stored goods from pollution and static shock.
- AC power 85V~265V 50/60Hz, compatible for worldwide application.
- Smart Control System and resettable target humidity.



DRY30EA

Outer dimensions: W300*D300*H431mm
Draw: 1
Power : AC85~265V 50/60HZ
Average Power: 6W
Humidity Range: 25~50%RH



DRY55EA

Outer dimensions: W350*D350*H551mm
Draw: 1
Power : AC85~265V 50/60HZ
Average Power: 6W
Humidity Range: 25~50%RH



DRY80EA

Outer dimensions: W380*D380*H661mm
Draw: 1
Power : AC85~265V 50/60HZ
Average Power: 6W
Humidity Range: 25~50%RH

- Application: for drying, baking, temp testing, heat aging, or sterilizing in mining industries, electronics, labs, research institutes, and other industries.
- Safety structure mirror, stainless steel made inner container, and high quality steel for outer cabinet.
- LED display and microcomputer control, LCD display optional.
- Door glass with wide view for user's observation convenience.
- Nano-material for door sealing and insulation on material for heat preservation.
- Variety of blast drying ovens, vacuum drying ovens, incubators, and constant temperature/humidity cabinets, for your option!



VERTICAL VACUUM DRYING OVEN(250°C)



VERTICAL BLAST DRYING OVEN(250°C)



ULTRA HIGH TEMP DRYING OVEN(400°C)



DESK TYPE VACUUM DRYING OVEN(250°C)



DESK TYPE BLAST DRYING OVEN(250°C)



FLAMMABLE SAFETY CABINETS

RoHS CE ISO9001



- Designed to meet American standards of OSHA and NFPA (CODE 30), for regulated storage of flammable, combustible, and hazardous materials.
- Double-walled steel structure with 1.5" (38mm) insulation for fire resistance.
- Welded 1.2mm thickness steel offers optimum longevity with increased heat resistance
- Three-point locking system with two keys for security, available for optional Master Lock to limit access to authorized personnel.
- 2" (50mm) leakproof sump for spills containment.

- Normative safety signage in large red lettering.
- Two vents with integral flame arrestors
- Adjustable spill-catching shelves, adjust by 2 1/4" (6cm) up/down
- Cabinets are epoxy painted for both inner and outer.
- Grounding connector for antistatic earthing, as per OSHA standard.



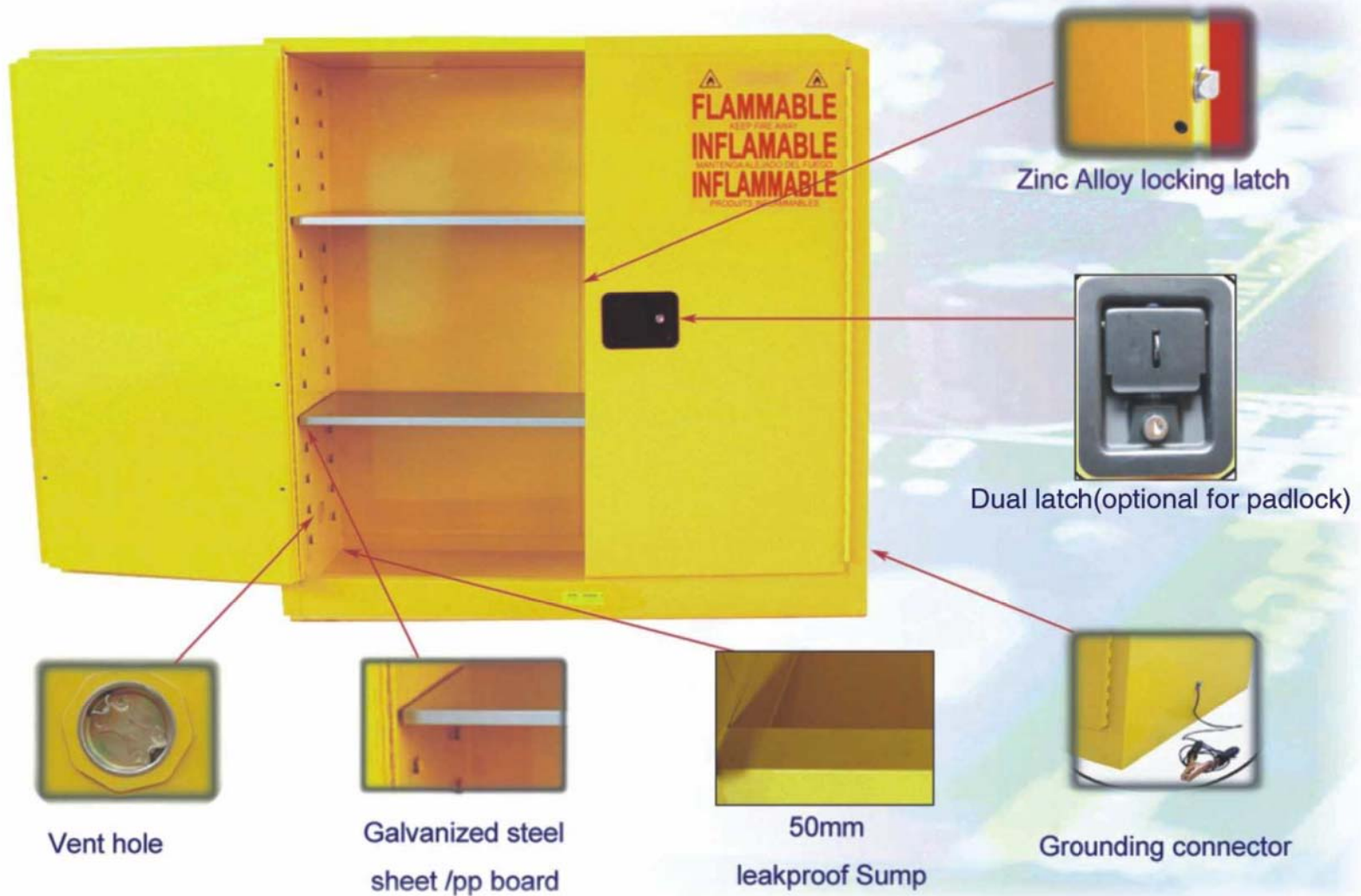



Technical details of flammable safety

Model name	Material	Length	Width	Thickness	Applicable spec	Remarks
Shelf	Galvanized steel sheet	348	330	25	CFS-G004	For STD spec
Shelf	Galvanized steel sheet	508	360	25	CFS-G012	
Shelf	Galvanized steel sheet	1008	360	25	CFS-G030 CFS-G045	
Shelf	Galvanized steel sheet	778	760	25	CFS-G060	
Shelf	Galvanized steel sheet	1008	760	25	CFS-G090	For options
Pallet	Galvanized steel sheet/pp board	340	330	10/58	CFS-G004	
Pallet	Galvanized steel sheet/pp board	500	330	10/58	CFS-G012	
Pallet	Galvanized steel sheet/pp board	1000	330	10/58	CFS-G030 CFS-G045	
Pallet	Galvanized steel sheet/pp board	770	760	10/58	CFS-G060	
Pallet	Galvanized steel sheet/pp board	1000	760	10/58	CFS-G090	

Spec	Capacity (liters)	Outer dimension (H*W*D/CM)	Outer dimension (H*W*D/CM)	Weight (kg)	Parts
CFS-G004	15	56*43*43	46*35*33	34	One door/manual, 1 shelf, one earthing cable
CFS-G012	45	89*59*46	79*51*36	60	One door/manual, 1 shelf, one earthing cable
CFS-G022	83	165*60*46	155*52*36	90	One door/manual, 3 shelves, one earthing cable
CFS-G030	114	112*109*46	102*101*36	100	2 doors/manual, 1 shelf, one earthing cable
CFS-G045	170	165*109*46	155*101*36	138	2 doors/manual, 2 shelves, one earthing cable
CFS-G054	204	165*60*87	155*52*77	136	2 doors/manual, 3 shelves, one earthing cable
CFS-G060	207	165*86*86	155*78*76	165	2 doors/manual, 2 shelves, one earthing cable
CFS-G090	340	165*109*86	155*101*76	190	2 doors/manual, 2 shelves, one earthing cable

- Yellow indicates flammable liquids
- Red indicates combustible liquids
- Blue indicates weak acids and weak bases



Application:

Supermarkets, stores, big malls, hotels, guesthouses, cafeteria, KTV, night clubs, bars, hospitals, drugstores, theme parks, amusement park, waterparks, zoos, tourist spots, libraries, exhibition halls, museums, stations, airports, government buildings, courts, procuratorates, prisons, etc.

Spec	Outer dimension(mm)	Box dimension(mm)	Power / display	Color option
CT12	W830*D430*H1800	W270*D410*H280	85~220V 50/60Hz Power consume: Standby 8W Working 30W Display: 128*64 lattice with backlighting	Blue, Green, Red, etc.
CT18	W1250*D430*H1800			
CT24	W1670*D430*H1800			
CT36	W2301*D430*H1800			

Features:

- High grade 1mm and 1.2mm cold rolled plate, reinforced structure, high intensity bearing and anti-erosion.
- Convenient for stuff storage and taking-out.
- Advanced thermal printer for barcode printing and paper cutting system.
- Advanced reader for 100% barcode recognizing, even for bent barcode paper.
- Sound safety to avoid wrong taking.
- Barcodes with digitals for clear checking.
- Reliable emergency system: When system error occurs and the door can not open or the barcode slip is lost or can not be read, the administrator can use the administration key to open any compartments. Even if the power is off, the compartments can also be opened.
- Friendly clear LCD wide screen for operation instruction.
- Local radio host recording for instruction words.
- Auto infrared detection for storage safety.
- Reliable data recording for checking.
- Best usage of your space.
- CE and RoHS certified.
- Options: barcode, IC card, ID card, or coin.





CATEC Intelligent Storage Solution, effects the new logistical storage concept of "from articles to operator" with number of carriers as storage unit in the carousel, to circulate the carriers by rotating chains. The articles will be delivered to the operator accurately and in the shortest time.

The intelligent storage system is applicable for storage of tools, spare parts, electronic components, medicines, medical appliances, files, documents, disks, optics, and other materials to be circulated in any area. This application covers wide range of fields, such as electronic, aviation, tobacco, mechanical, chemical, petrochemical, pharmaceutical, bank, defense industry, automobile, and so on.

Features:

- Automatic working, saving your time
- Plentiful usage of the available space
- Reliable safety for your items, with multi-password management
- FIFO function
- Various operation modes for working convenient: manual or automatic operation for single carousel and /or automatic networking operation are all workable.
- Hand crank is workable when power off or machine malfunction.
- Humidity control for 1-60%RH is the option for MSD to be stored.
- Networking administration is the option for higher efficiency.



Changshu Catec Electronic Equipment INC.

Эксклюзивный дистрибьютор в России:

ООО "Евроинтех"
140011, Московская область, г. Люберцы,
ул. Юбилейная, д. 26
Телефон мобильный: +7-(495)-749-45-78
Тел./факс: +7-(495)-228-72-04
E-mail: sales@eurointech.ru
<http://www.eurointech.ru/catec>